

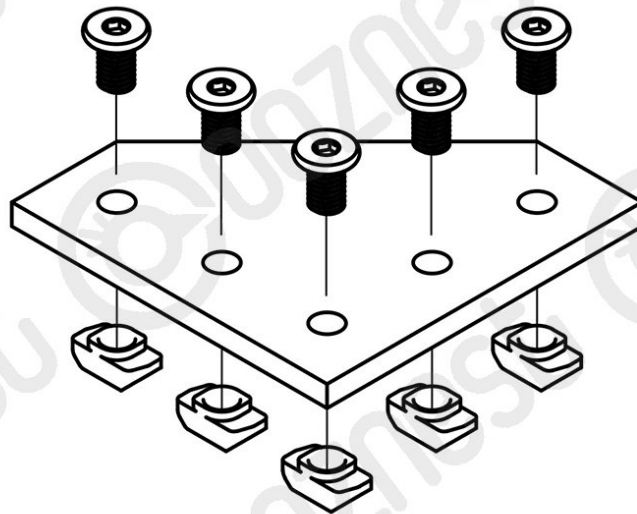

1. Preparing Hardware

Written By: Robert



Step 1 — Preparing the Corner-Joining-Plates

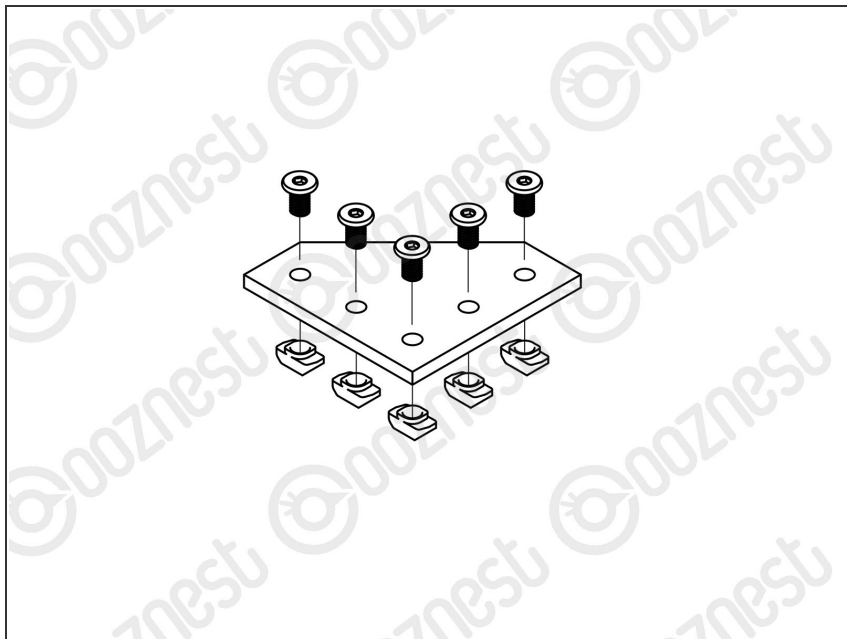

- Using the M5-Button-Head-Bolt-8mm provided and M5-Drop-In-Tee-Nuts construct all Corner-Joining-Plates as pictured.

⚠ Do not tighten the M5-Drop-In-Tee-Nuts as they need to be loose to engage with the extrusion.

Step 2 — Preparing the T-Joining-Plate

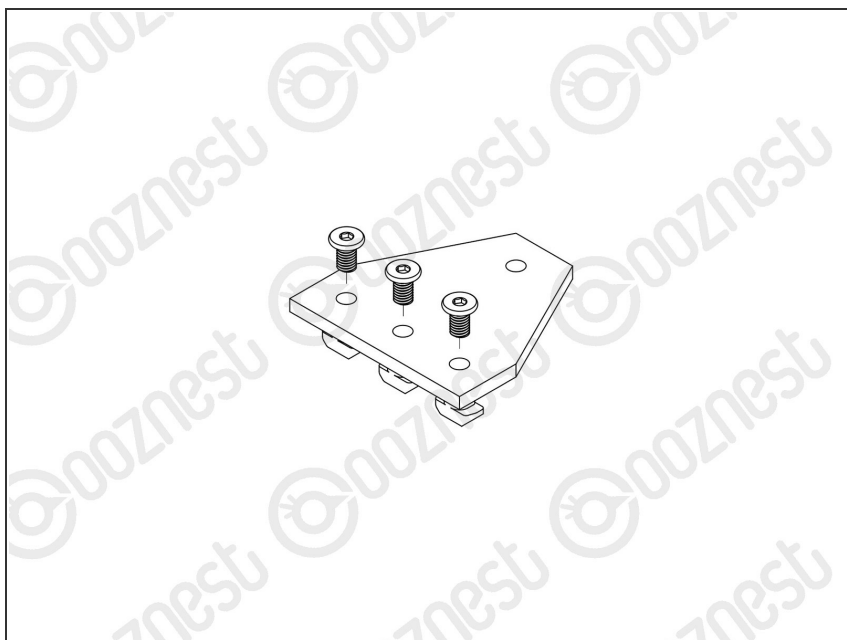

- Using the M5-Button-Head-Bolt-8mm provided and M5-Drop-In-Tee-Nuts construct the T-Joining-Plate as pictured.

⚠ Do not tighten the M5-Drop-In-Tee-Nuts as they need to be loose to engage with the extrusion.

Step 3 — Preparing the Universal-L-Brackets

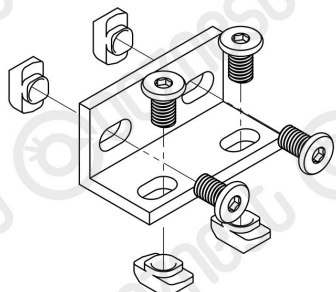

- Using the M5-Button-Head-Bolt-8mm provided and M5-Drop-In-Tee-Nuts construct 10 x Universal-L-Brackets as pictured.

⚠ Do not tighten the M5-Drop-In-Tee-Nuts as they need to be loose to engage with the extrusion.

Step 4 — Preparing the Door-Hinges

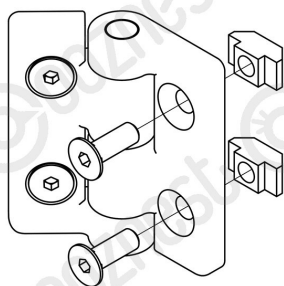

- Using the M5-Button-Head-Bolt-8mm provided and M5-Drop-In-Tee-Nuts construct all Door-Hinges as pictured.

⚠ Do not tighten the M5-Drop-In-Tee-Nuts as they need to be loose to engage with the extrusion.

Step 5 — Preparing the Maker-Links

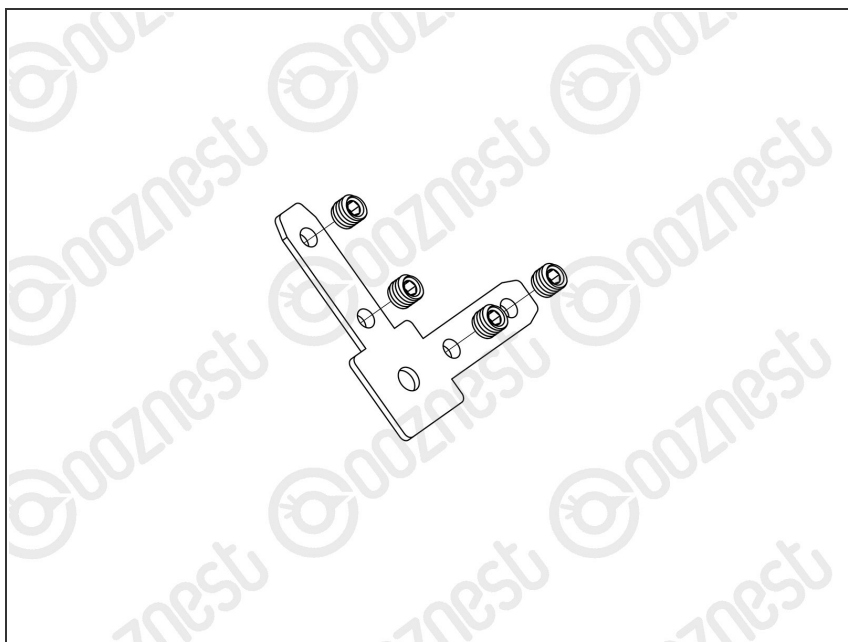

- Thread the grub screws into the Maker-Links until they hold themselves in place.

Step 6 — Preparing the Door-Handles

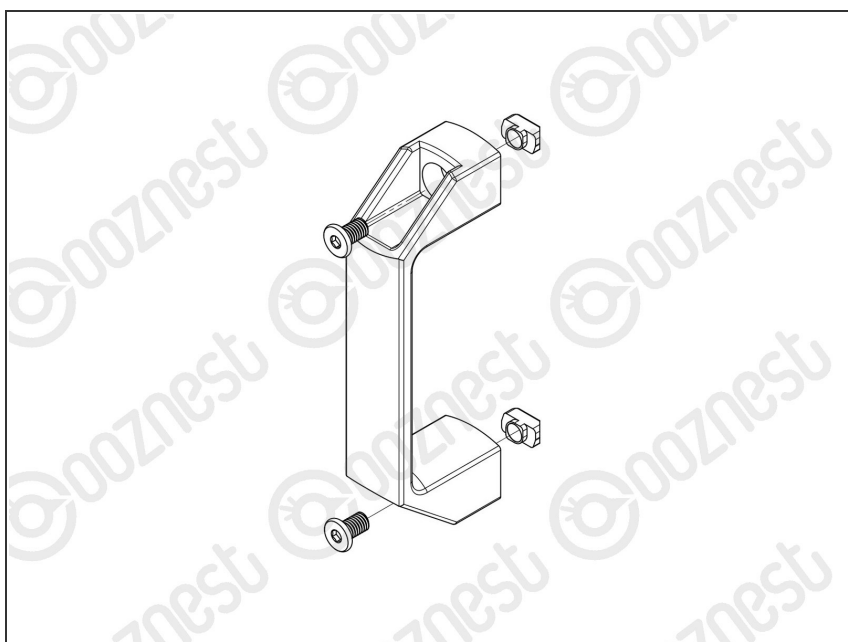

- Using the M5-Button-Head-Bolt-10mm provided and M5-Drop-In-Tee-Nuts construct all Door-Handles as pictured.
- ⚠ Do not over tighten the M5-Drop-In-Tee-Nuts as they need to be loose enough to engage with the extrusion profile.

Step 7 — Preparing Fix Down Universal-L-Brackets

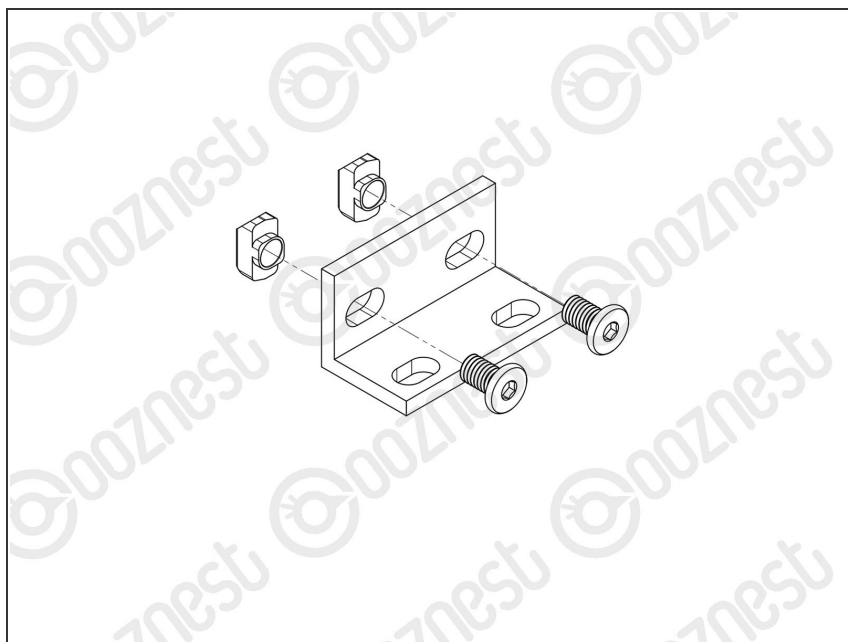

- Using the M5-Button-Head-Bolt-8mm provided and M5-Drop-In-Tee-Nuts construct 4 x Universal-L-Brackets as pictured. Use these brackets to secure the Enclosure to your work surface.

⚠ Do not over tighten the M5-Drop-In-Tee-Nuts as they need to be loose enough to engage with the extrusion profile.

Step 8 — Guide Complete



- Guide Complete - Proceed to [2. Assembling The Enclosure Doors](#)

Thanks for following the guide. Any issues, please contact us!