

MOTECH MOTOR CO., LTD

Product Name

Hybrid Stepper Motor
MT-1703HSM168A

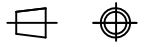

Rev A

Made by

P.T

Approve

Martin

Date

12/25/2016

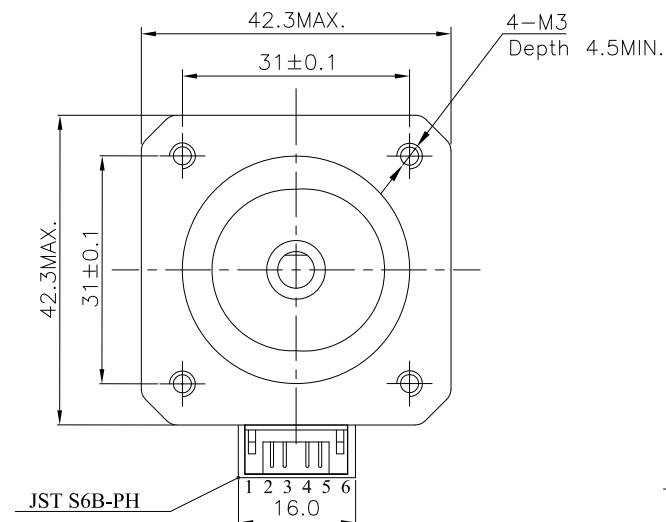
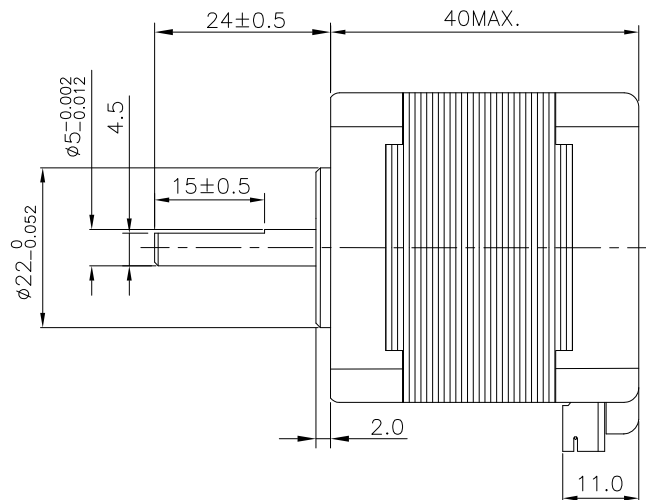

P/N: Cables

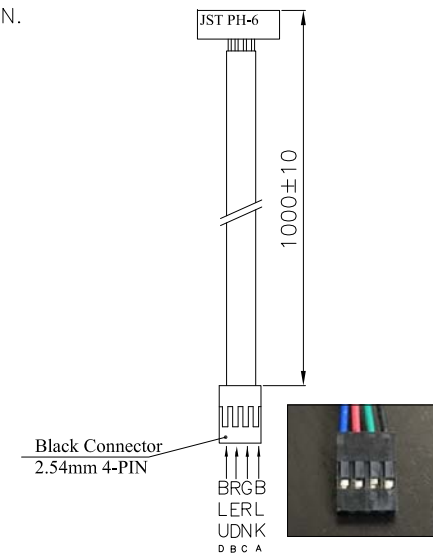

Items	Specs	Items	Specs
Phase Number	2 phases	Step Angle	0.9°±5%
Rated Voltage	2.8 VDC	Rated Current	DC 1.68 A / Phase
Resistance(20°C)	1.65±10% Ω / phase	Inductance	3.6±20% mH / Phase
Holding Torque	≥ 3.5 Kg-cm	Detent Torque	220 g-cm REF.
Rotate Direction	ABCD A CW	MAX Starting PPS	2500 PPS
MAX slewing PPS	2500 PPS	Insulation Resistance	≥100 MΩ(DC 500V)
HI POT	AC600V/1mA/1S	Insulation Class	Class B
Rotor Inertia	54 g.cm ²	Weight	0.28 Kg REF.

Wiring Diagram

